

### DESCRIPTION

Single acting piston seal for pneumatic cylinders

### MATERIAL

Type: Polyurethane  
Designation: SEALPUR 93  
Hardness: 93 °ShA

### MAIN FEATURES

It is a U-shaped single acting piston seal that can also be mounted "back to back" to get the doubling acting effect.

The asymmetric lips are designed to differentiate the behavior of the lips on the static and dynamic surfaces: the dynamic lip is flexible, more sensitive to pressure fluctuations and with a special rounded lip designed for pneumatic application to maintain lubricating film and minimize friction; the static lip is longer and stronger to concentrate load against the static surface.

The material used to produce this seal is a polyurethane compound, specifically developed for the production of pneumatic seals, that ensures excellent properties on wear-resistance, extended service life and low permanent deformation.

- Simple groove design
- Geometry of the sealing lips is designed to operate with air lubricated and dry
- Low friction at all usage pressure
- Easy installation without expensive auxiliaries
- Excellent wear-resistance
- Extended service life

### FIELD OF APPLICATION

Pressure	≤ 20 bar
Speed	≤ 1 m/s
Temperature	-35°C ÷ +80°C
Fluids	Air with or without lubrication, grease, mineral oils, non-aggressive gases, etc.

### SURFACE ROUGHNESS

Dynamic surface	Ra ≤ 0.25 μm	Rt ≤ 2.5 μm
Static surface	Ra ≤ 0.8 μm	Rt ≤ 6.3 μm

### LEAD-IN CHAMFERS

D	S <sub>MIN</sub>
• less 20	3 mm
• 20÷50	4 mm
• 51÷150	5 mm
• over 150	6 mm

- to avoid damaging the sealing lips during installation, housing must have rounded chamfers. Sharp edges and burrs within the installation area of the seal must be removed

Part.	D <sup>H10</sup>	d <sup>h9</sup>	L <sup>+0.2</sup>	M
<b>GPP 6 3 2</b>	6	3	2.5	5.6
<b>GPP 8 4 2.55</b>	8	4	3	5.5
<b>GPP 8 4 8 2.3</b>	8	4.8	2.7	7.6
<b>GPP 9 5 3.25</b>	9	5	3.5	6.5
<b>GPP 10 6 2.55</b>	10	6	3	7.5
<b>GPP 12 7 2.55</b>	12	7	3	9
<b>GPP 13 8 2.55</b>	13	8	3	10
<b>GPP 14 8 2.55</b>	14	8	3	10

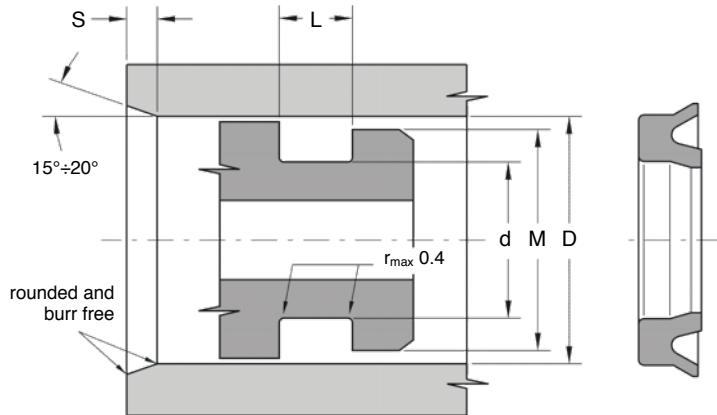

Part.	D H10	d h9	L +0.2	M
GPP 16 10 2.55	16	10	3	12
GPP 17 11 2.55	17	11	3	13
GPP 18 12 2.55	18	12	3	14
GPP 20 14 2.55	20	14	3	16
GPP 22 16 2.55	22	16	3	18
GPP 25 17 5.5	25	17	6	20
GPP 25 19 3.25	25	19	3.5	21
GPP 30 22 3.25	30	22	3.5	25
GPP 32 24 3.25	32	24	3.5	27
GPP 32 24 5.5	32	24	6	27
GPP 36 28 3.25	36	28	3.5	31
GPP 40 30 7	40	30	7.5	34
GPP 40 32 3.25	40	32	3.5	35
GPP 42 30 6	42	30	6.5	34
GPP 42 34 3.25	42	34	3.5	37
GPP 45 37 3.25	45	37	3.5	40
GPP 50 40 7	50	40	7.5	44
GPP 50 42 3.25	50	42	3.5	45

Part.	D H10	d h9	L +0.2	M
GPP 52 42 4.25	52	42	4.5	46
GPP 55 45 7	55	45	7.5	49
GPP 58 48 4.25	58	48	4.5	52
GPP 60 50 5	60	50	5.7	54
GPP 60 50 7	60	50	7.5	54
GPP 63 53 4.25	63	53	4.5	57
GPP 63 53 7	63	53	7.5	57
GPP 65 55 7	65	55	7.5	59
GPP 70 58 8.5	70	58	9.5	62
GPP 70 60 7	70	60	7.5	64
GPP 80 68 8.5	80	68	9.5	72
GPP 80 70 4.25	80	70	4.5	74
GPP 90 80 4.25	90	80	4.5	84
GPP 100 88 8.5	100	88	9.5	92
GPP 100 90 4.25	100	90	4.5	94
GPP 120 105 10	120	105	11	110
GPP 125 105 8.25	125	105	8.5	112
GPP 125 110 10	125	110	11	115
GPP 130 115 10	130	115	11	120
GPP 140 120 8.25	140	120	8.5	127
GPP 155 135 8.25	155	135	8.5	142
GPP 160 140 8.25	160	140	8.5	147
GPP 160 140 8.4	160	140	9.4	151
GPP 254 244 5.7	254	244	6.3	248