

DESCRIPTION

Double acting piston seal for pneumatic cylinders

MATERIAL ON DYNAMIC SURFACE

Type: Polyurethane
Designation: SEALPUR 93
Hardness: 93 °ShA

MATERIAL ON STATIC SURFACE

Type: Nitrile Rubber NBR
Designation: RUBSEAL 70
Hardness: 70 °ShA

MAIN FEATURES

The seal type KPDP has been specially developed for pistons of double-acting cylinders and is composed of:

- a dynamic seal element in polyurethane that ensures excellent wear-resistance and good sealing performance.
- a standard size O-Ring with low permanent deformation as energizing component on the static side.

The polyurethane used to produce the dynamic element is a compound, specifically developed for the production of pneumatic seals, that ensures excellent properties on wear-resistance, extended service life and low permanent deformation.

- Space-saving construction
- Simple groove design

- Excellent wear-resistance
- Extended service life
- Low cost solution
- Easy installation without expensive auxiliaries
- High resistance to pressure peaks

FIELD OF APPLICATION

Pressure	over 20 bar
Speed	≤ 1 m/s
Temperature	-35°C ÷ +80°C
Fluids	Air with or without lubrication, grease, mineral oils, non-aggressive gases, etc.

SURFACE ROUGHNESS

Dynamic surface	Ra ≤ 0.25 μm	Rt ≤ 2.5 μm
Static surface	Ra ≤ 0.8 μm	Rt ≤ 6.3 μm

LEAD-IN CHAMFERS

D	S _{MIN}
• less 20	3 mm
• 20÷50	4 mm
• 51÷150	5 mm
• over 150	6 mm

- to avoid damaging the sealing lips during installation, housing must have rounded chamfers. Sharp edges and burrs within the installation area of the seal must be removed

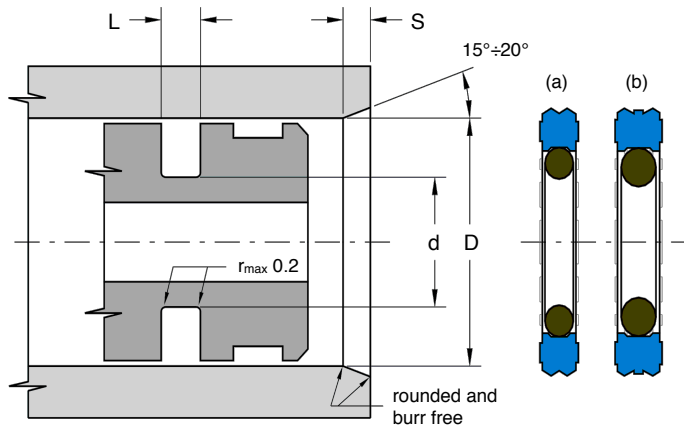

Part.	D ^{H10}	d ^{h9}	L ^{+0.2}	OR	Tp.
KPDP 16 9 2.5	16	9	2.5	611	(a)
KPDP 20 13 2.5	20	13	2.5	014	(a)
KPDP 25 18 2.5	25	18	2.5	017	(a)
KPDP 32 23 3	32	23	3	813	(a)
KPDP 35 26 3	35	26	3	120	(a)
KPDP 45 36 3	45	36	3	126	(a)
KPDP 63 51 4	63	51	4	226	(b)
KPDP 125 110 5	125	110	5	244	(b)